

## WSO Mist Collector

WSO 20, 25-1, 25-2 and 25-3

### Installation and Operation Manual

Installation, Operation, and Service Information

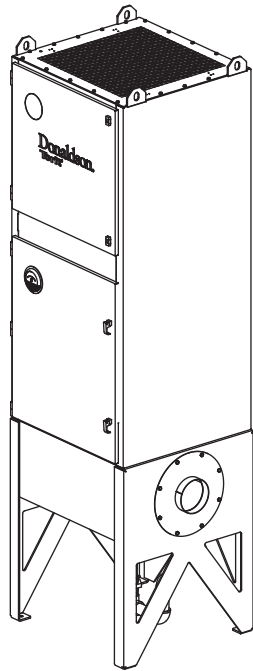

WSO 25-1

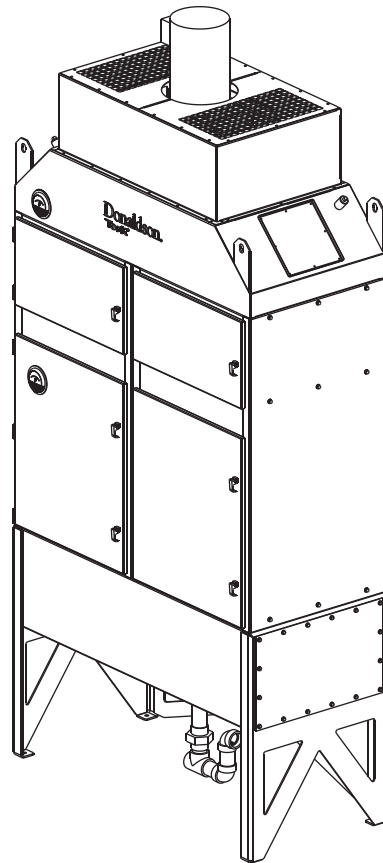

WSO 25-2

This manual is property of the owner. Leave with the unit when set-up and start-up are complete. Donaldson Company reserves the right to change design and specifications without prior notice.

Illustrations are for reference only as actual product may vary.



**This is the safety alert symbol. It is used to alert you to potential personal injury hazards. Obey all safety messages that follow this symbol to avoid possible injury or death.**

**WARNING**

Process owners/operators have important responsibilities relating to combustible hazards. Process owners/operators must determine whether their process creates combustible dust, fume, or mist. If combustible dust, fume, or mist is generated, process owners/operators should at a minimum:

- Comply with all applicable codes and standards. Among other considerations, current NFPA standards require owners/operators whose processes involve potentially combustible materials to have a current Hazard Analysis, which can serve as the foundation for their process hazard mitigation strategies.
- Prevent all ignition sources from entering any dust collection equipment.
- Design, select, and implement fire and explosion mitigation, suppression, and isolation strategies that are appropriate for the risks associated with their application.
- Develop and implement maintenance work practices to maintain a safe operating environment, ensuring that combustible dust, fume, or mist does not accumulate within the plant.

Donaldson recommends process owners/operators consult with experts to insure each of these responsibilities are met.

As a manufacturer and supplier of Industrial Filtration Products, Donaldson can assist process owners/operators in the selection of filtration technologies. However, process owners/operators retain all responsibility for the suitability of fire and explosion hazard mitigation, suppression, and isolation strategies. Donaldson assumes no responsibility or liability for the suitability of any fire and/or explosion mitigation strategy, or any items incorporated into a collector as part of an owner/operators hazard mitigation strategy.

Improper operation of a dust control system may contribute to conditions in the work area or facility that could result in severe personal injury and product or property damage. Check that all collection equipment is properly selected and sized for the intended use.

DO NOT operate this equipment until you have read and understand the instruction warnings in the Installation and Operations Manual. For a replacement manual, contact Donaldson Torit.

This manual contains specific precautionary statements relative to worker safety. Read thoroughly and comply as directed. Discuss the use and application of this equipment with a Donaldson Torit representative. Instruct all personnel on safe use and maintenance procedures.

**Data Sheet**

Model Number _____	Serial Number _____
Ship Date _____	Installation Date _____
Customer Name _____	
Address _____	
_____	
Filter Type _____	
Accessories _____	
Other _____	



## Contents

Description.....	1	Maintenance Information.....	15
Purpose and Intended Use.....	1	Operational Checklist .....	15
Rating and Specification Information.....	2	Filter Removal and Installation.....	15
Operation.....	3	First Stage Filter Cleaning and Installation .....	15
Inspection on Arrival.....	4	Primary Filter Installation .....	16
Installation Codes and Procedures .....	4	Final Filter Installation (WSO 20 and 25-1).....	17
Installation.....	4	Final Filter Installation (WSO 25-2 and 25-3) .....	17
Site Selection, Grade-Mounted Units .....	4	P-Trap Service .....	18
Site Selection, Ceiling-Mounted Units (WSO 20		P-Trap with Y-Strainer, Screen Cleaning and Removal	18
and 25-1): .....	5	Drain Collection Container.....	19
Unit Location.....	5	Optional Equipment.....	20
Rigging Instructions.....	6	Factory-Installed HEPA/95% DOP Filter.....	20
Hoisting Information .....	6	Field Installation (WSO 20 and 25-1) .....	20
Electrical Wiring.....	6	Latch and Afterfilter Installation .....	20
Standard Equipment.....	7	Magnehelic® or Minihelic® Installation.....	21
Typical Floor Mount Installation .....	7	Remote-Mount Magnehelic Installation .....	21
Blower and Motor (Unpowered WSO 25-2 and 25-3).....	9	Damper and Silencer, TBI.....	23
Ceiling Mount (WSO 20 and 25-1).....	11	Sprinkler Installation.....	24
P-Trap Installation .....	12	WSO 20 Sprinkler Installation.....	24
Inlet Collar Installation .....	12	WSO 25-1 Sprinkler Installation .....	25
Electrical Connection .....	13	WSO 25-2 and 25-3 Sprinkler Installation.....	25
Motor Starter Control Box .....	13	Drain Collection Container.....	25
Preliminary Start-Up Check .....	14	Troubleshooting.....	26

Magnehelic® and Minihelic® are registered trademarks of Dwyer Instruments, Inc.



**DANGER** indicates a hazardous situation which, if not avoided, will result in death or serious injury.



**WARNING** indicates a hazardous situation which, if not avoided, could result in death or serious injury.



**CAUTION**, used with the safety alert symbol, indicates a hazardous situation which, if not avoided, could result in minor or moderate injury.



**NOTICE** is used to address practices not related to personal injury that may result in damage to equipment.

## Description

Designed for versatility, the WSO (Water, Smoke, and Oil) mist collector is specifically engineered for water-based, smoke, and oil-based mist applications. WSO mist collector, Models WSO 20, 25-1, 25-2, and 25-3 collect airborne mist such as oil, water-soluble, semi-synthetic and synthetic coolant from machining operations. Two stages of filtration, plus an optional HEPA or 95% DOP filter, provide a cleaner, healthier work environment as well as a more cost effective means of mist collection. With maximum airflow capacities up to 2,000 cfm for WSO 20 and 25-1 and 5,500 cfm for WSO 25-2 and 25-3, the WSO is a strategic component to meeting industrial and government air-quality standards. The high efficiency filter cartridges allow air and coolants to be recycled.

Designed to increase the versatility of the unit, a variety of filter media specifically designed for mist collection is a standard offering on the product line. The WSO 20 contains a 20 inch tall primary filter and the WSO 25-1, 25-2, and 25-3 contain a 25 inch tall primary filter uniquely designed for either water-based coolants, straight oils, or thermally-generated smoky applications. Standard options include drain collection containers, P-Traps, and afterfilters.

WSO models 20 and 25-1 include the blower and motor. WSO models 25-2 and 25-3 are available with or without a blower and motor.

## Purpose and Intended Use



Misuse or modification of this equipment may result in personal injury.

Do not misuse or modify.

Airborne mist is small droplets of metalworking fluids suspended in the air. Metalworking fluids include straight oils, water-soluble coolants, semi-synthetic and synthetic coolants. These fluids perform a variety of functions such as lubricating or cooling the part or the tool, flushing chips away from the part, and suppressing dust and smoke.

Mist is created two ways: mechanical action or thermal effects. Mechanical action involves coolant used for light lubrication and generally creates mist greater than one micron in size. Thermal effects occur when heat vaporizes the coolant, the vapor cools and recondenses into a mist. Thermal effects create mist from 0.01 to 1 micron in size. Other contaminants, such as dust from the part or the tool or smoke from the vaporization of the oil or coolant are also generated when using metalworking fluids.

The WSO mist collector is not designed to handle water mist alone. There should be some type of oil content to allow coalescing or water vapor will simply pass through the filters. The extremes of very heavy oil and light, thin oil should be avoided. Very heavy oil, similar to tar consistency, will not drain while very light, thin oil, similar to paint thinner consistency, may evaporate.



Combustible materials such as buffing lint, paper, wood, metal dusts, weld fume, or flammable coolants or solvents represent potential fire and/or explosion hazards. Use special care when selecting, installing, and operating all dust, fume, or mist collection equipment when such combustible materials may be present in order to protect workers and property from serious injury or damage due to a fire and/or explosion.

Consult and comply with all National and Local Codes related to fire and/or explosion properties of combustible materials when determining the location and operation of all dust, fume, or mist collection equipment.

Standard Donaldson Torit equipment is not equipped with fire extinguishing or explosion protection systems.

## Rating and Specification Information

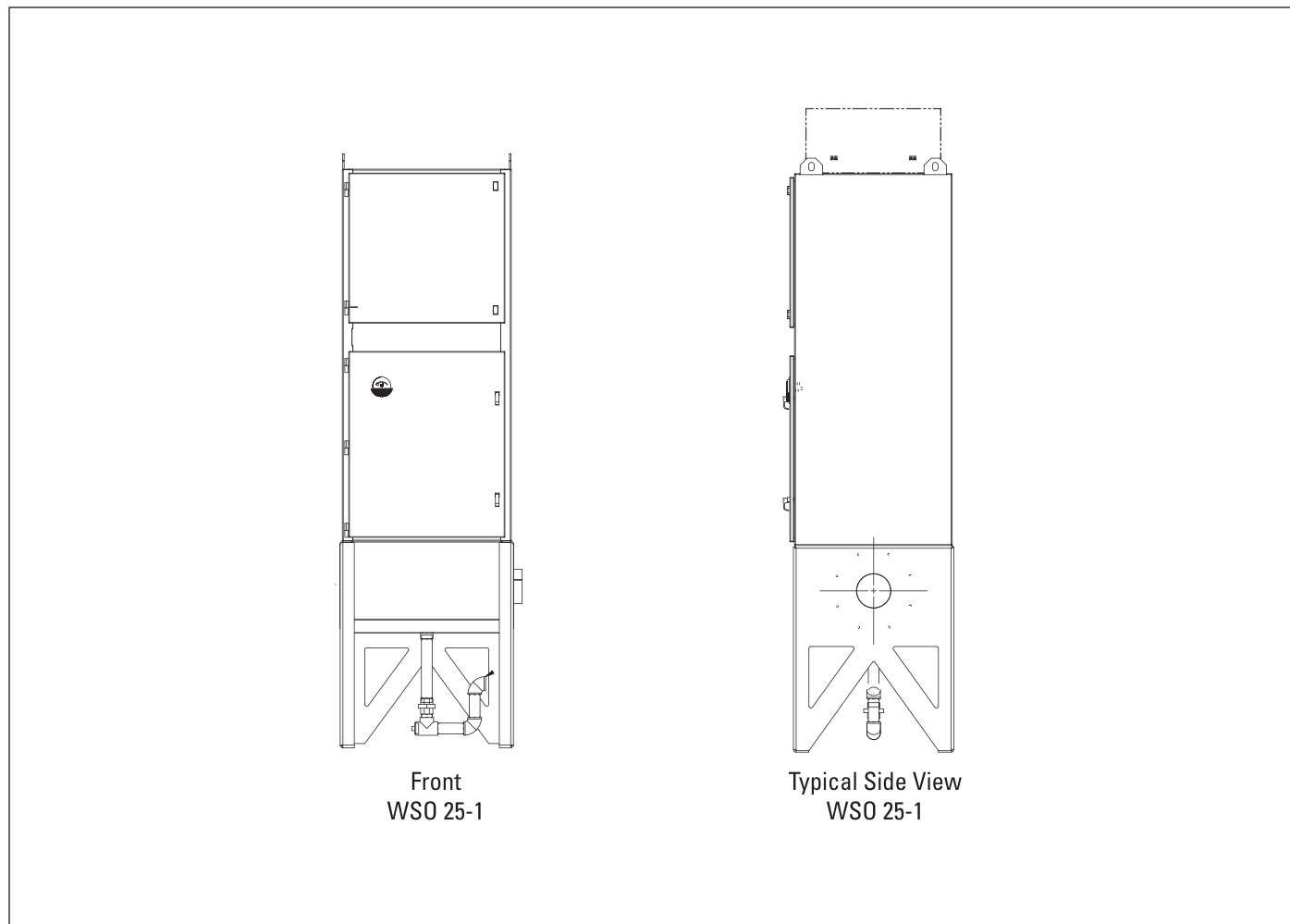

All Units (as per IBC 2006 Specifications\*):

Seismic Spectral Acceleration,  $S$  .....1.5 g  
 Seismic Spectral Acceleration,  $S_1^S$  .....0.6 g  
 Installed Unit Base Elevation .....Grade  
 Occupancy Category..... 1.0  
 Housing rating, inches water gauge ..... +/- 20  
 Power and controls ..... 200-Volt, 380-Volt, 3 Ph, 50Hz/60 Hz

\*If unit was supplied with a Record Drawing, the specifications on the drawing will supersede the standard specifications above.

## Operation

During normal operation, contaminated air enters the unit through one or both dirty-air inlets located on each side, toward the bottom of the unit. The incoming air slows and turns upward, causing large mist droplets and particles to fall out of the air stream and into the hopper. The air passes through a reusable first-stage filter designed to collect and coalesce large droplets and particles.

The primary stage of filtration is the pleated filter cartridge specifically designed to collect, coalesce, and drain fine mist. As the mist coalesces, the droplets are big enough to run down the cartridge and drain back into the collector. The droplets will drain on both the inside and outside of the cartridge. Liquid that collects on the inside of the cartridge drains through the bottom portion of the porous media and into the hopper. Clean, mist-free air exits the cartridge and discharges through the top of the collector.

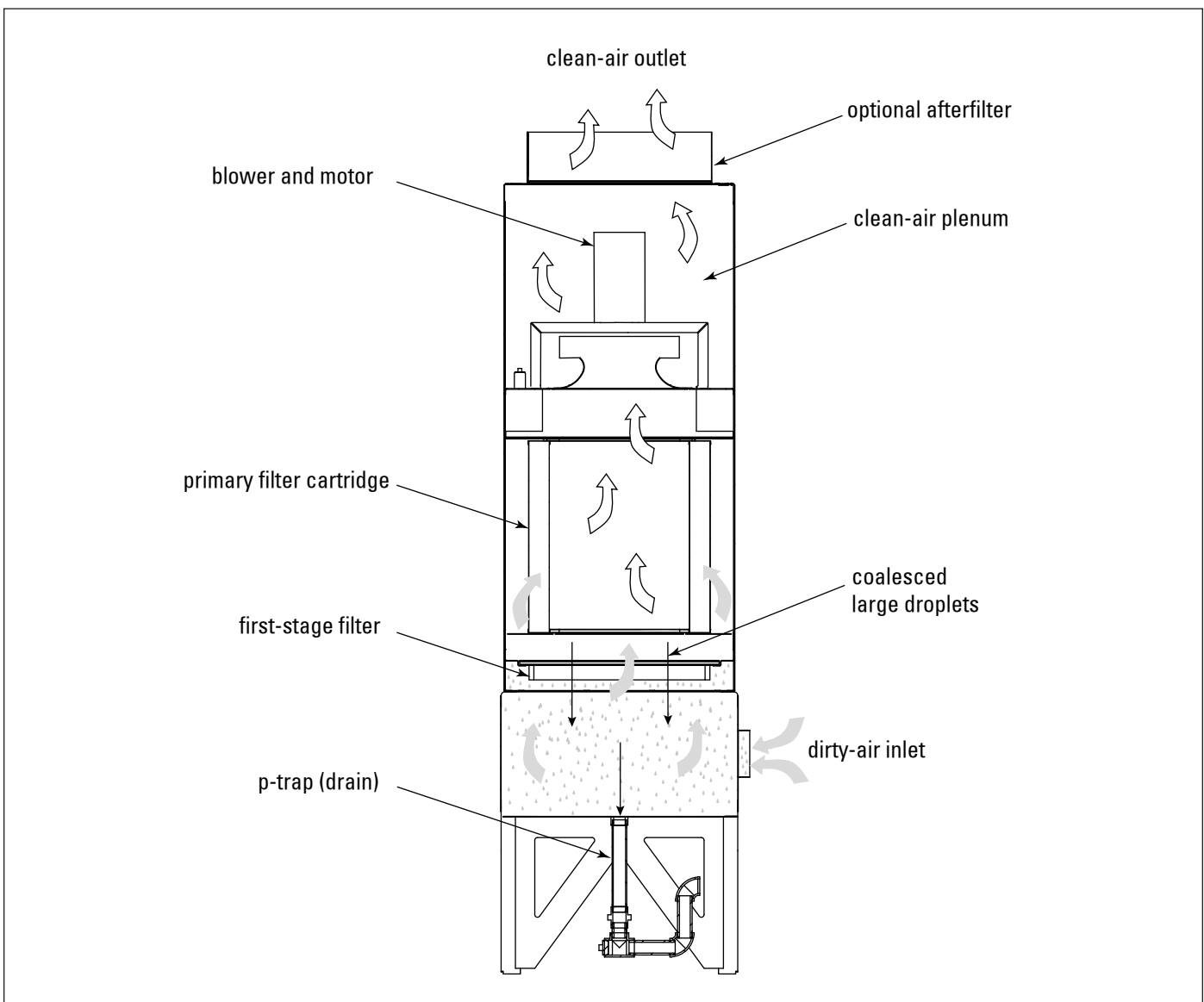

Unit Operation, WSO 25-1 shown

## Inspection on Arrival

1. Inspect unit on delivery.
2. Report any damage to the delivery carrier.
3. Request a written inspection report from the Claims Inspector to substantiate any damage claim.
4. File claims with the delivery carrier.
5. Compare unit received with description of product ordered.
6. Report incomplete shipments to the delivery carrier and your Donaldson Torit representative.
7. Remove crates and shipping straps. Remove loose components and accessory packages before lifting unit from truck.
8. Check for hardware that may have loosened during shipping.
9. Use caution removing temporary covers.

## Installation Codes and Procedures



Codes may regulate recirculating filtered air in your facility.

Consult with the appropriate authorities having jurisdiction to ensure compliance with all national and local codes regarding recirculating filtered air.

Safe and efficient operation of the unit depends on proper installation.

Authorities with jurisdiction should be consulted before installing to verify local codes and installation procedures. In the absence of such codes, install unit according to the National Electric Code, NFPA No. 70-latest edition and NFPA 91 (NFPA 654 if combustible dust is present).

A qualified installation and service agent must complete installation and service of this equipment.

All shipping materials, including shipping covers, must be removed from the unit prior to, or during unit installation.

### **NOTICE**

Failure to remove shipping materials from the unit will compromise unit performance.

Inspect unit to ensure all hardware is properly installed and tight prior to operating collector.

## Installation



Site selection must account for wind, seismic zone, and other live-load conditions when selecting the location for all units.

Codes may regulate acceptable locations for installing dust collectors. Consult with the appropriate authorities having jurisdiction to ensure compliance with all national and local codes regarding dust collector installation.

### Site Selection, Grade-Mounted Units



Ensure weight of oil-laden unit plus weight of required materials and equipment will be adequately supported. Failure to comply may result in personal injury and/or property damage.

### **NOTICE**

When outdoor locations are selected, always mount motors with drain holes pointed down for proper drainage of moisture.

The unit can be located on a flat reinforced concrete foundation.

Provide clearance from heat sources and interference with utilities when selecting the location.

Prepare the foundation in the selected location. Install anchor bolts a minimum of 1 3/4-inches above foundation.

Locate the collector to ensure easy access to electrical and compressed-air connections and routine maintenance.

## Site Selection, Ceiling-Mounted Units (WSO 20 and 25-1):

### CAUTION

Lifting lugs on the unpowered unit (25-2 or 25-3) are not intended for ceiling suspension. Unit is floor-mount only. Failure to comply may result in personal injury and/or property damage.

Ensure weight of oil-laden unit plus weight of required materials and equipment will be adequately supported. Failure to comply may result in personal injury and/or property damage.

WSO 20 and 25-1 can be suspended or hung from overhead supports. The supports must be adequate to carry the live load of the unit and installation performed to reduce sway or vibration to the unit. The dry unit weight is shown on the specification control drawing shipped with the unit.

The live load will include the weight of all ancillary hardware attached to the mist collector, as well as the weight of the mist-laden, wet filters. Consult the coolant MSDS for the specific gravity of the coolant to estimate the weight of the mist-laden, wet filters.

Provide clearance from heat sources and interference with utilities when selecting the location for suspended units.

## Unit Location

### WARNING

Donaldson Torit equipment is not designed to support site-installed ducts, interconnecting piping, or electrical services. All ducts, piping, or electrical services supplied by others must be adequately supported to prevent severe personal injury and/or property damage.

When hazardous conditions or materials are present, consult with local authorities for the proper location of the collector.

### CAUTION

If combustible materials will be processed through this collector, local codes may require the collector be located either outside or adjacent to an exterior wall to accommodate devices related to a fire or explosion mitigation strategy. Consult local codes prior to installation.

Foundation or overhead (for WSO 20 and 25-1) support must be sized to accommodate the entire weight of the unit, plus the weight of the collected material, piping, and ductwork.

## Rigging Instructions

### Suggested Tools & Equipment

Clevis Pins and Clamps	Lifting Slings
Crane or Forklift	Pipe Sealant
Drift Pins	Pipe Wrenches
Drill and Drill Bits	Screwdrivers
End Wrenches	Socket Wrenches
Adjustable Wrench	Spreader Bars
Torque Wrench (inch/lbs, 9/16-in Socket)	

### Hoisting Information



Failure to lift the collector correctly can result in severe personal injury or property damage.

Use appropriate lifting equipment and adopt all safety precautions needed for moving and handling the equipment.

A crane or forklift is recommended for unloading, assembly, and installation of the collector.

Location must be clear of all obstructions, such as utility lines or roof overhang.

Use all lifting points provided.

Use clevis connectors, not hooks, on lifting slings.

Use spreader bars to prevent damage to unit's casing.

Check the Specification Control drawing for weight and dimensions of the unit and components to ensure adequate crane capacity.

Allow only qualified crane operators to lift the equipment.

Refer to applicable OSHA regulations and local codes when using cranes, forklifts, and other lifting equipment.

Lift unit and accessories separately and assemble after unit is in place.

## Electrical Wiring



Electrical service or maintenance work must be performed by a qualified electrician and comply with all applicable national and local codes.

Turn power off and lock out electrical power sources before performing service or maintenance work.

Do not install in classified hazardous atmospheres without an enclosure rated for the application.

The only component requiring electrical power is the blower motor. For the unpowered WSO 25-2 and 25-3 models, the blower motor is configured separately from the unit. The blower motor can be mounted on the floor or on the roof of the unit for the unpowered WSO 25-2 and 25-3 models.

All electrical wiring and connections, including electrical grounding, should be made in accordance with the National Electric Code, NFPA No. 70-latest edition.

Check local ordinances for additional requirements that apply.

The appropriate wiring schematic and electrical rating must be used. See unit's rating plate for required voltage.

An electric disconnect switch having adequate amp capacity should be installed in accordance with Part IX, Article 430 of the National Electrical Code, NFPA No. 70-latest edition. Check unit's rating plate for voltage and amperage ratings.

Refer to the wiring diagram for the number of wires required for main power wiring and remote wiring.

## Standard Equipment

### **CAUTION**

The collector has a high center-of-gravity and may overturn if not secured properly.

Secure the collector to the lifting device.

Use care when moving the unit.

The WSO mist collector is shipped in two sections, an inlet plenum with legs and a filter cabinet section with a blower and motor (for powered WSO 20 and 25-1 models) or without a blower and motor (for unpowered WSO 25-2 and 25-3 models).

### Typical Floor Mount Installation

1. Prepare the foundation in the selected location. Install customer-supplied 3/8-16 anchor bolts a minimum of 1 1/2-inches above foundation. Anchor bolt pattern is shown on the Specification Control drawing.
  2. Using a crane or forklift, raise the inlet plenum to the required height.
- Note: When using a crane, use clevis pins and a sling attached to four lifting lugs.
3. For the WSO 20, attach legs to the outside of the unit's stub legs with supplied fasteners. Do not tighten hardware at this time.
  4. Lower the inlet plenum with legs to the anchor bolts.
  5. Level inlet plenum and secure all hardware.

6. Apply supplied sealant to the top flange of the inlet plenum.
7. Remove the first stage and primary filters from the filter cabinet and set aside.
8. Using a crane or forklift, raise the filter cabinet section to the required height. See below illustration for correct lifting orientation.
9. Set cabinet on top of the inlet plenum flange and attach with the supplied fasteners.
10. Remove crane or forklift.
11. Re-install the first stage and primary filters.

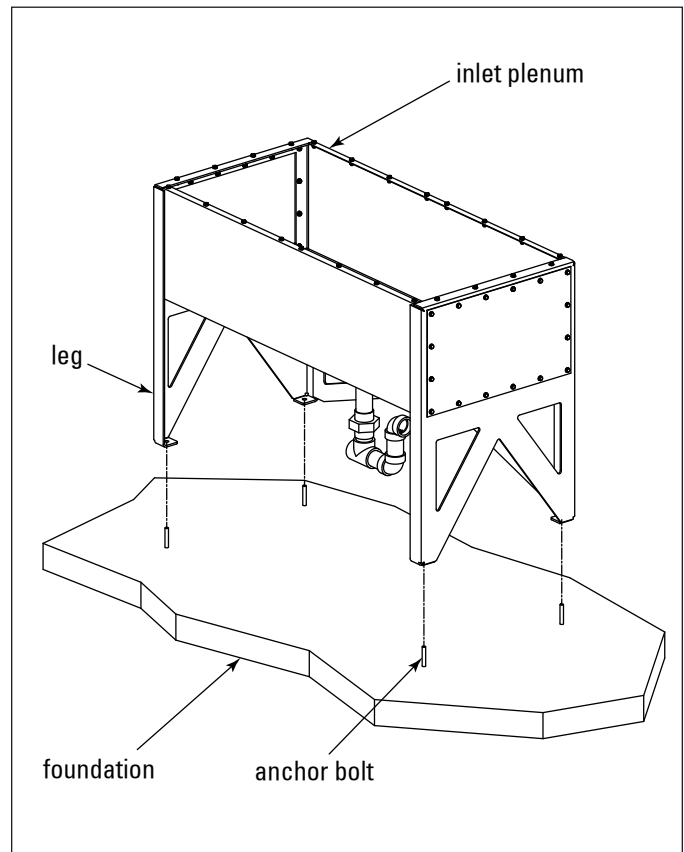

Inlet Plenum Installation, WSO 25-2 shown

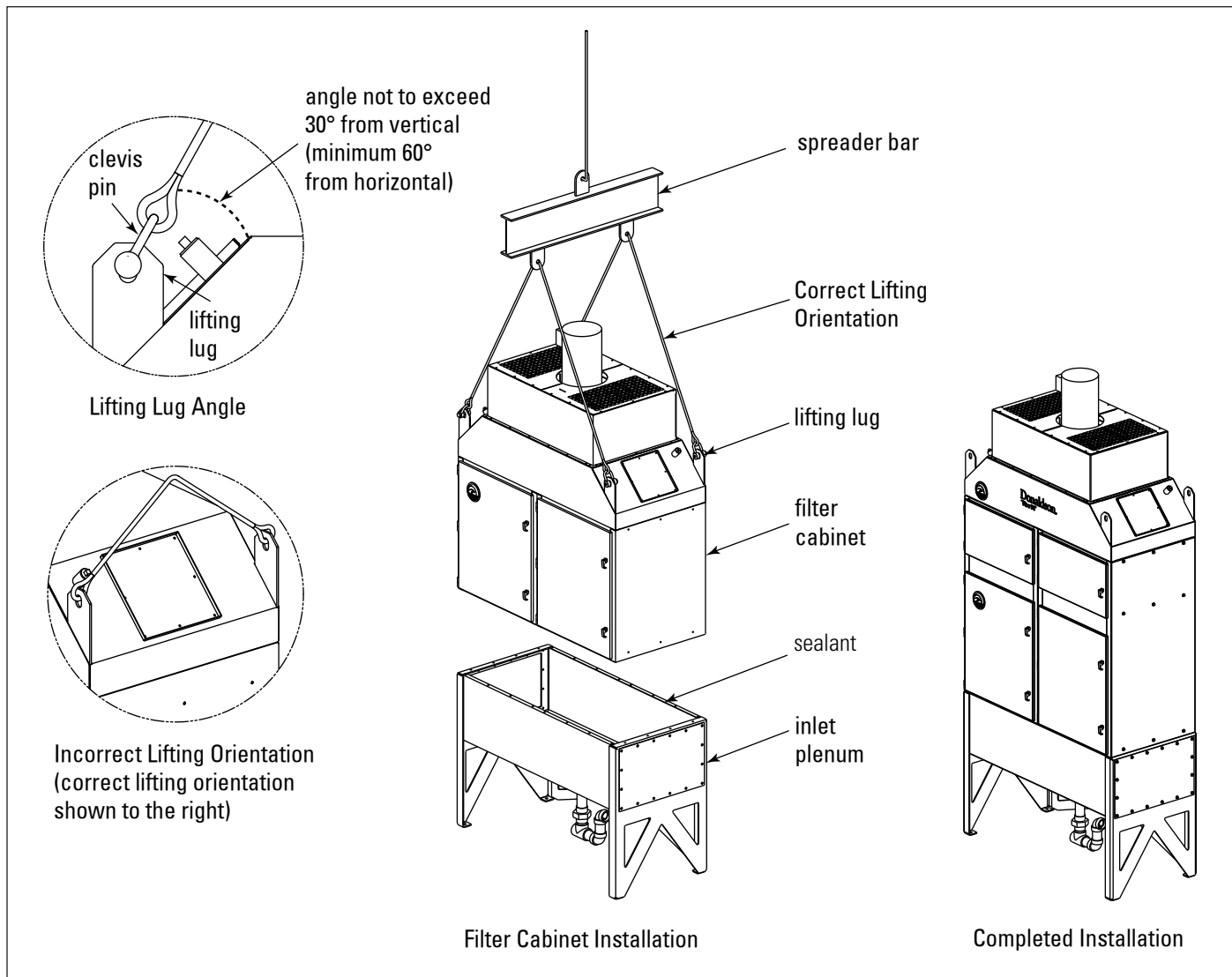

Completed Installation, Powered WSO 25-2 shown

### Blower and Motor (Unpowered WSO 25-2 and 25-3)

The two types of blowers, Torit Backward Incline, TBI, and Torit Radial Blade, TRB, are installed following the same procedure. Both can be ordered for top mount.

1. The blower and motor are shipped assembled and partial disassembly is required before installing.
2. Remove eight motor-mount bracket fasteners; remove the motor, motor-mount bracket, and blower wheel as an assembly as shown.
3. Turn housing over and apply sealant to the outside-edge of the bolt pattern on the blower housing. Mount the blower housing to the collector using the inlet cone fasteners.
4. Apply sealant to the outside-edge of the bolt pattern on the blower housing. Reinstall the motor, bracket, and blower wheel assembly. Align the tab on the blower housing with the slot in the motor-mount bracket.
5. Rotate blower wheel after installation to ensure proper clearance between the inlet cone and the blower wheel.



Do not allow the fan wheel to come loose from the motor as it

may cause severe injury or property damage. To ensure proper attachment of the fan wheel:

Tighten all setscrews in fan wheel.\*

Tighten all setscrews in bearings.\*

Repeat after 8 hours of operation.

Repeat again after two weeks of operation.

Reference Wheel Setscrew Torque Table.

Setscrew Size Diameter	Carbon Steel Setscrew Torque*	
	Lb. - In.	Lb. - Ft.
In.		
1/4	75	6.2
5/16	144	12
3/8	252	21
7/16	396	33
1/2	600	50
5/8	1164	97
3/4	2016	168
7/8	3204	267
1	4800	400

\*Stainless steel setscrews are not hardened and should not be tightened to more than half of the values shown.

#### Wheel Setscrew Torque

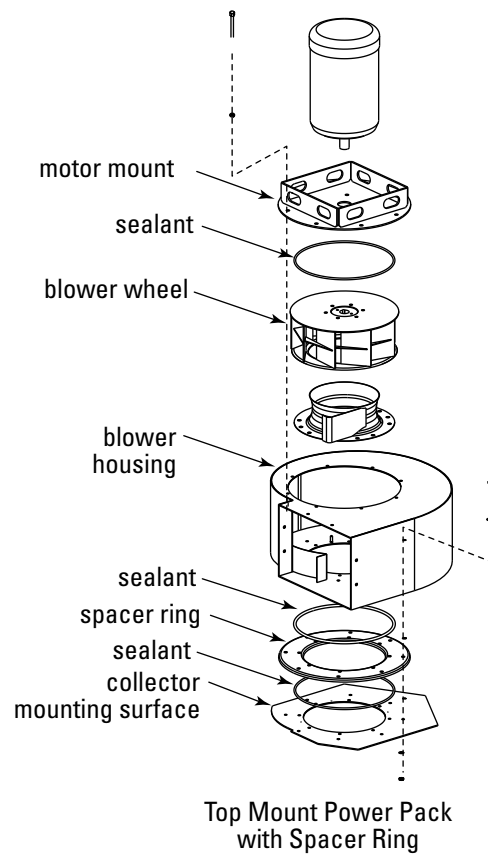

Blower and Motor, TBI with Spacer Ring

## Ceiling Mount (WSO 20 and 25-1)

### **CAUTION**

Failure to lift the collector correctly can result in severe personal injury or property damage.

Use appropriate lifting equipment and adopt all safety precautions needed for moving and handling the equipment.

A crane or forklift is recommended for unloading, assembly, and installation of the collector.

Location must be clear of all obstructions, such as utility lines or roof overhang.

Ensure weight of oil-laden unit plus weight of required materials and equipment will be adequately supported. Failure to comply may result in personal injury and/or property damage.

1. Verify that the ceiling attachment points can bear the live load.
2. Use properly sized cable or chain to attach to each of the four WSO attachment lugs (WSO 25-1) or eyebolts (WSO 20) to suspend the unit from the ceiling.
3. To prevent sway, position the chain or cable to form a 60 degree angle to the top of the unit and a 45 degree angle along the sides.

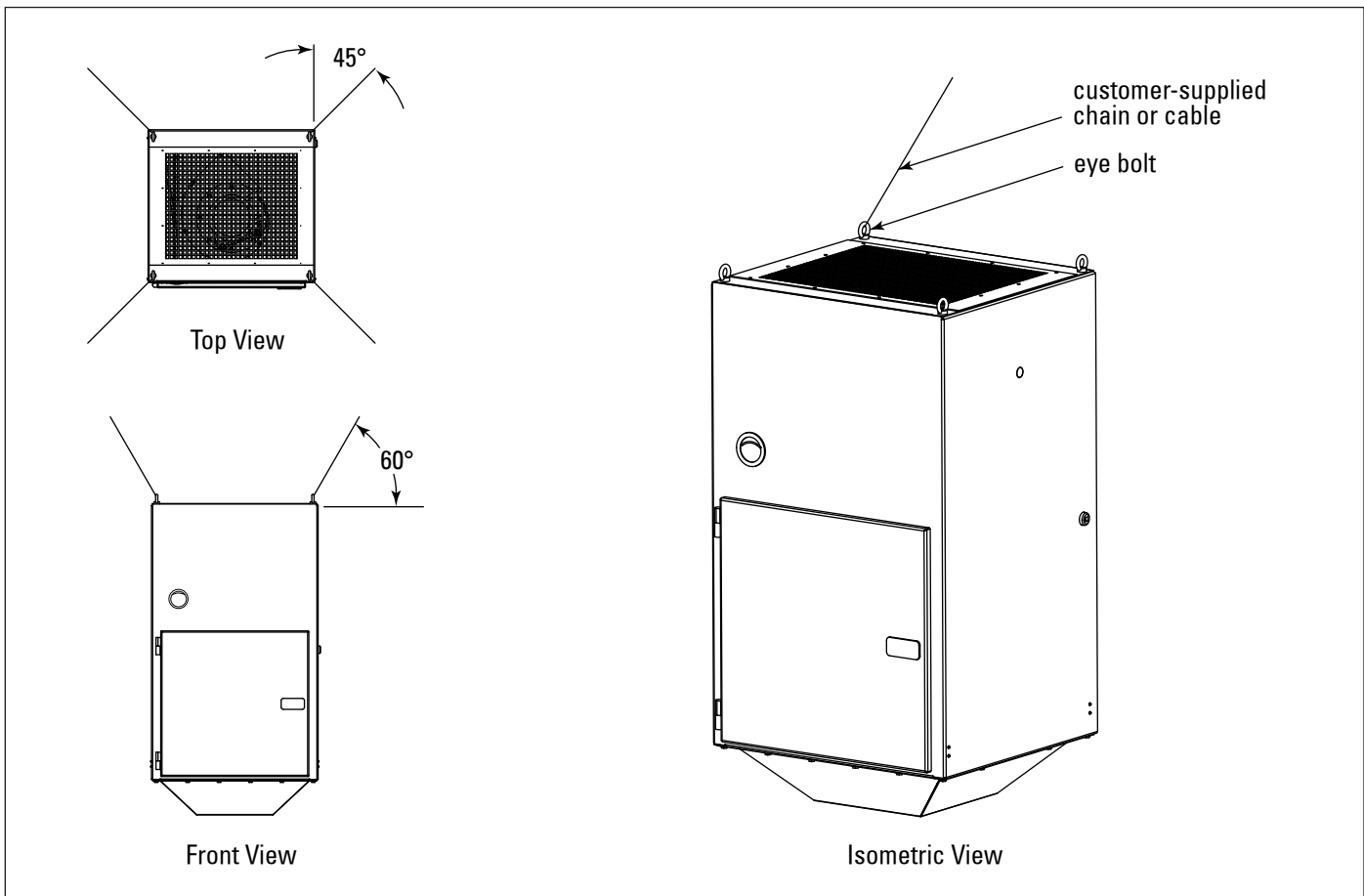

Ceiling Mount Installation, WSO 20 shown

## P-Trap Installation

### NOTICE

Ensure collected material properly flows through the P-Trap. The P-Trap dimensions should accommodate a column of coolant greater than the static capacity of the fan to avoid coolant pooling in the collector and potentially causing property damage.

1. Install the P-Trap as shown in P-Trap Installation.
2. Position the P-Trap outlet to the proper location and tighten the union.
3. Plumb the P-Trap to a receptacle or install a return line back to the machine center.
4. Fill P-Trap before starting unit.

Note: The characteristics of some machining fluids change with time, use, and exposure to air. Check the condition of the collected fluid before re-using.

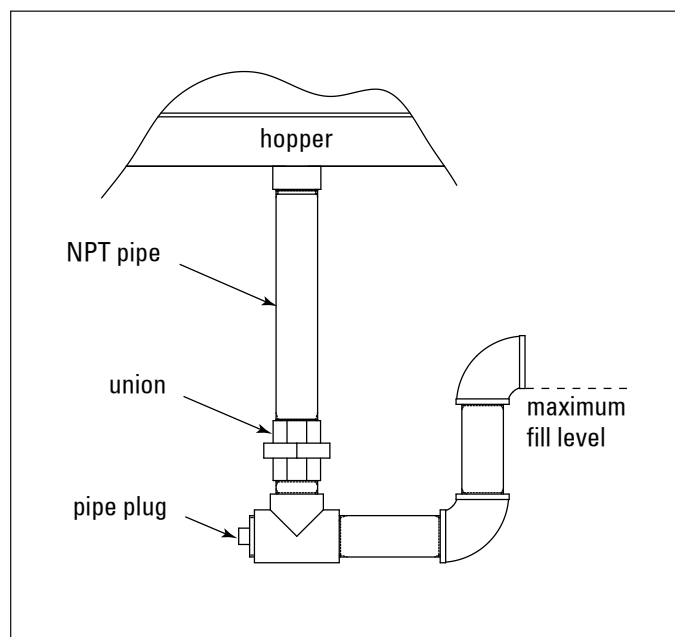

P-Trap Installation

## Inlet Collar Installation

### (WSO 20 and 25-1)

1. Install the inlet collar to the desired inlet location using the supplied sealant and hardware.
2. For single-inlet configurations, install the inlet blank to the inlet opposite the inlet collar using the supplied sealant and hardware.

### (WSO 25-2 and 25-3)

1. Refer to the Specification Control Drawing to get the dimensions and bolt pattern of the inlet. Typically, a rectangle-to-round transition, custom to your particular installation, is obtained from the ducting supplier. Install the rectangle-to-round transition to the desired inlet location using the supplied sealant and hardware.
2. For single-inlet configurations, install the inlet blank to the inlet opposite the inlet collar using the supplied sealant and hardware.

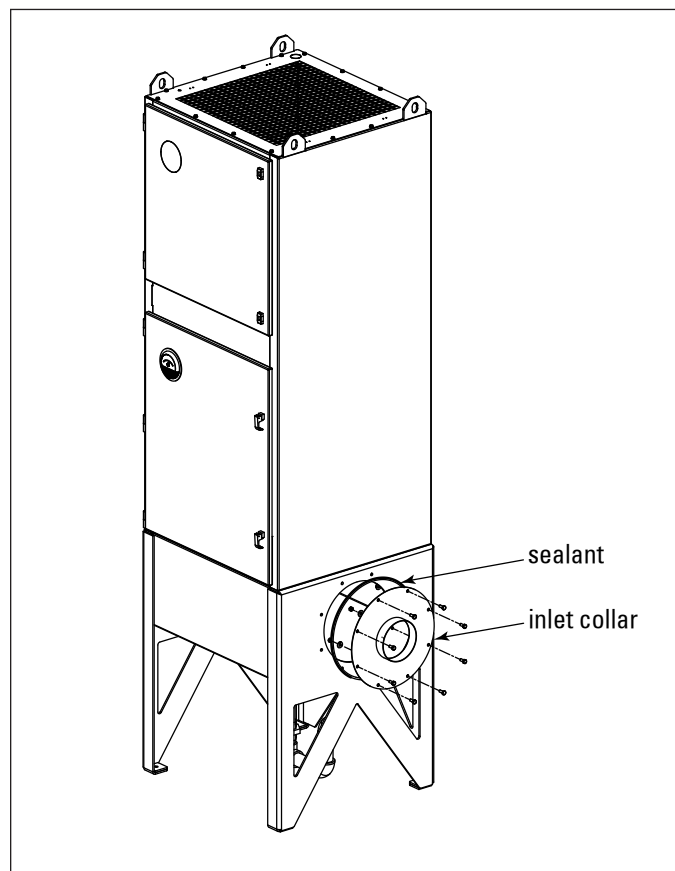

Inlet Collar Installation, WSO 25-1 shown

## Electrical Connection (WSO 20, 25-1, and Powered WSO 25-2, 25-3)

### **⚠ WARNING**

Electrical service or maintenance work must be performed by a qualified electrician and comply with all applicable national and local codes.

Turn power off and lock out electrical power sources before performing service or maintenance work.

Do not install in classified hazardous atmospheres without an enclosure rated for the application.

WSO mist collectors must be equipped with a customer-supplied safety disconnect with short circuit protection, contactors, and overload protection. Complete the wiring as shown in Motor Starter Wiring.

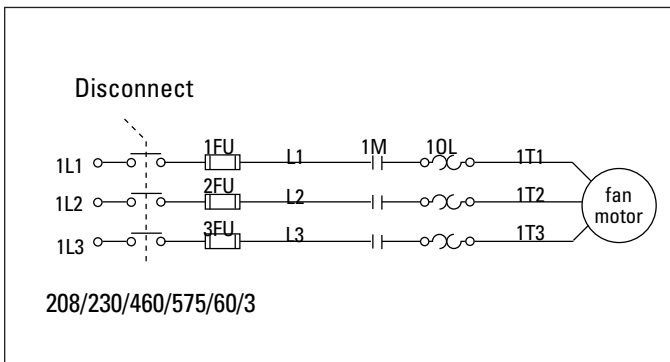

Motor Starter Wiring

## Motor Starter Control Box

Mount the motor starter control box in a convenient location. For the WSO 20 and 25-1, an electrical knockout, sized for 1/2-in fittings, is provided on the left-hand side of the blower cabinet. Increase knockout size using a drill as required.

- Using the wiring diagram supplied inside the control box and the instructions on the motor decal, make the connections to the blower motor.

**Note:** If the unit is supplied with an optional junction box, wire the motor starter to the terminal strip located inside the junction box according to the wiring diagram supplied with the junction box.

- Turn the blower motor ON then OFF and check for proper rotation: clockwise for WSO 25-1, powered WSO 25-2 and 25-3 and see rotation arrow on the motor's mounting plate for WSO 20.

To reverse rotation, three-phase power supply: Turn electrical power OFF at source, properly lock-out power, and switch any two leads on the output-side of the blower motor starter.

### **⚠ WARNING**

Do not interchange a power lead with the ground wire. Severe personal injury or equipment damage may result.

Do not look into fan outlet to determine rotation. View the fan rotation from the back of the motor.

Check that the exhaust plenum is free of tools or debris before checking blower/fan rotation.

Stand clear of exhaust to avoid personal injury.

- Ground cabinet according to local electric codes.

## Preliminary Start-Up Check

Instruct all personnel on safe use and maintenance procedures.

### **WARNING**

Electrical work during installation must be performed by a qualified electrician and comply with all applicable national and local codes.

Turn power off and lock out electrical power sources before performing service or maintenance work.

Turn compressed air supply OFF and bleed lines before performing service or maintenance work

Check that the collector is clear and free of all debris before starting.

Do not install in classified hazardous atmospheres without an enclosure rated for the application.

Optional fans over 600 lbs must be independently supported.

1. Check all electrical connections for tightness and contact.
2. Motor and fan should be wired for clockwise rotation when viewed from the back of the motor.

To reverse rotation, three-phase power supply:  
Turn electrical power OFF at source and switch any two leads on the motor junction box.

### **WARNING**

Do not interchange a power lead with the ground wire. Severe damage or personal injury may result.

3. Check that all filters are properly installed.
4. All access panels should be sealed and secure.
5. Check that exhaust damper is set to the fully-closed position.
6. Check and remove all loose items in or near the inlet and outlet of the unit.
7. Check that all remote controls and solenoid enclosures (if applicable) are properly wired and all service switches are in the OFF position.

8. Check that hopper discharge is open and the storage container is sealed, if equipped.
9. Fill P-Trap if equipped, or close faucet valve on drain collection container if used.
10. Check that all optional accessories are installed properly and secured.
11. Turn blower fan motor ON.

### **WARNING**

Do not look into fan outlet to determine rotation. View the fan rotation through the back of the motor.

Check that the exhaust plenum is free of tools or debris before checking blower/fan rotation.

Stand clear of exhaust to avoid personal injury.

12. Adjust airflow with the exhaust damper.

### **NOTICE**

Excess airflow can shorten filter life, cause electrical system failure, and blower motor failure.

## Maintenance Information

Instruct all personnel on safe use and maintenance procedures.

### **WARNING**

Use proper equipment and adopt all safety precautions needed for servicing equipment. Electrical service or maintenance work must be performed by a qualified electrician and comply with all applicable national and local codes.

Turn power off and lock out electrical power sources before performing service or maintenance work.

Do not install in classified hazardous atmospheres without an enclosure rated for the application.

## Operational Checklist

1. Monitor the physical condition of the collector and repair or replace any damaged components.

Routine inspections will minimize downtime and maintain optimum system performance. This is particularly important on continuous-duty applications.

Periodically check the compressed air components and replace compressed air filters.

Drain moisture following the manufacturer's instructions. With the compressed air supply ON, check the cleaning valves, solenoid valves, and tubing for leaks. Replace as necessary.

2. Monitor pressure drop across filters.

Abnormal changes in pressure drop indicate a change in operating conditions and possibly a fault to be corrected. For example, prolonged lack of compressed air will cause an excess build-up of dust on the filters resulting in increased pressure drop. Cleaning off-line with no flow usually restores the filters to normal pressure drop.

3. Monitor exhaust.
4. Monitor hopper drainage. If slow or stopped, check hopper for obstructions and clean as necessary.
5. Check that the P-Trap is full. Refill if low or dry.

6. If equipped with a HEPA or 95% DOP, monitor pressure drop across after filter. Initial final filter pressure drop is approximately 1-2"wg. Replace the final filter when the gauge reads 3.5 to 4.0"wg. Do not attempt to clean or wash the final filter. Replace only.

### **NOTICE**

Do not operate the unit without the first- or primary-stage filter in place. Significant reduction in final filter life can result.

## Filter Removal and Installation

### **WARNING**

Use proper safety and protective equipment when removing contaminants and filters.

Dirty filters may be heavier than they appear.

Use care when removing filters to avoid personal injury.

## First Stage Filter Cleaning and Installation

Remove the first stage filter through the lower access door. Clean the first-stage screen by tapping it gently over an appropriate waste container. If further cleaning is required, wash in an appropriate wash tank. To clean the first-stage filter, soak in an appropriate wash tank, rinse, dry, and re-install.

### **NOTICE**

High temperature, steam-cleaning methods should not be used with the polypropylene filters due to the temperature limitations.

Do not operate the WSO mist collector without the first-stage filter in place. Significant reduction in primary filter life can result.

### Primary Filter Installation

Note: With the unit's airflow off, allow mist-laden, wet filter to drain into the inlet plenum for at least 15 minutes prior to removal.

1. Remove the filter cartridge by pulling the filter retention lever down to a horizontal position. Remove cartridge from unit and dispose of properly for the materials collected.

Note: A large plastic garbage bag placed over the top of the used filter allows cleaner filter change out. The filter can be tipped forward and out of the unit while the bag is pulled up over the bottom of the cartridge.

2. Place new filter on the filter retention platform, gasket side up. Slide filter back as far as it will go.

Note: The primary filter must be replaced. Do not wash.

3. Lift the filter retention lever up and close access door.

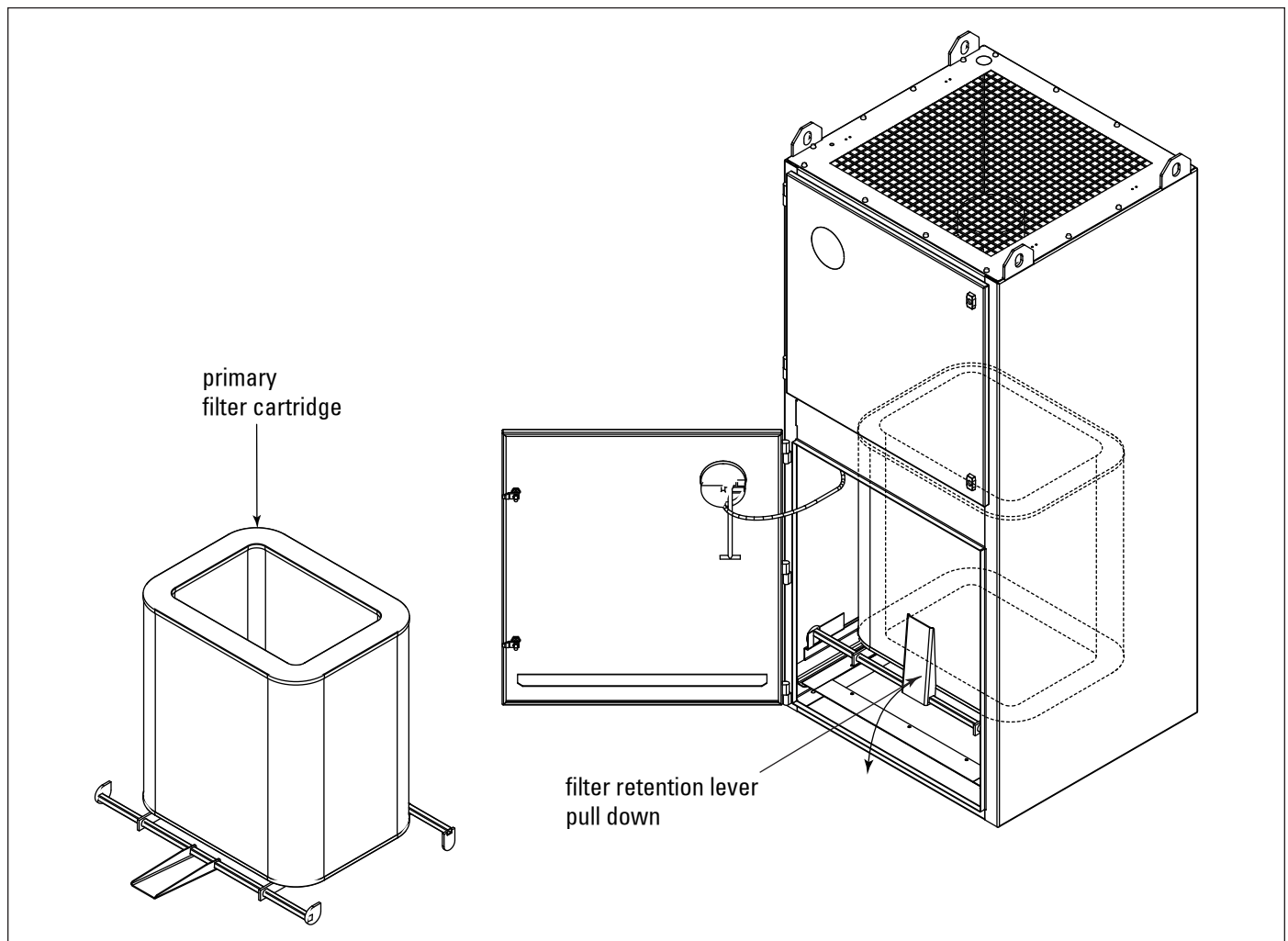

Primary Filter Replacement, WSO 25-1 shown

### Final Filter Installation (WSO 20 and 25-1)

Note: The final filter must be replaced. Do not wash.

1. Unlatch the final filter on top of the unit.
2. Remove the filter and dispose of properly for the materials collected.

#### **NOTICE**

Dirty filters may be heavier than they appear. Provide a support platform or have two people, one on each side of the filter and pull the filter out.

3. Install the replacement filter gasket-side down.
4. Latch the new filter in place.

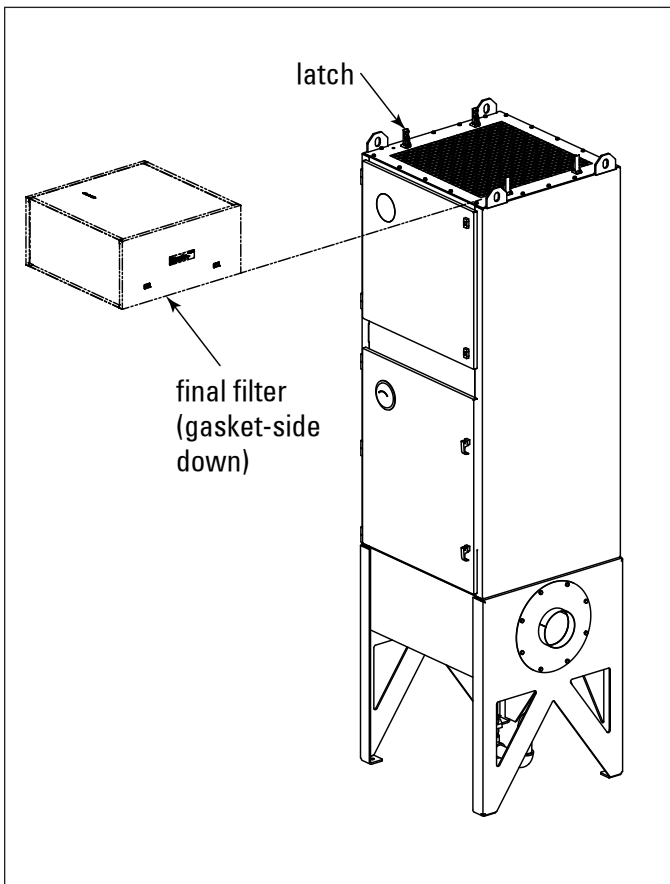

Final Filter Installation, WSO 25-1 shown

### Final Filter Installation (WSO 25-2 and 25-3)

Note: The final filter must be replaced. Do not wash.

1. Open the final filter access door and lower the retention handles to release the filter.
2. Remove the filter and dispose of properly for the materials collected.

#### **NOTICE**

Dirty filters may be heavier than they appear. Provide a support platform or have two people, one on each side of the filter and pull the filter out.

3. Install the replacement filter gasket-side up.
4. Seal the filter in place by lifting the retention handles to the upright position.

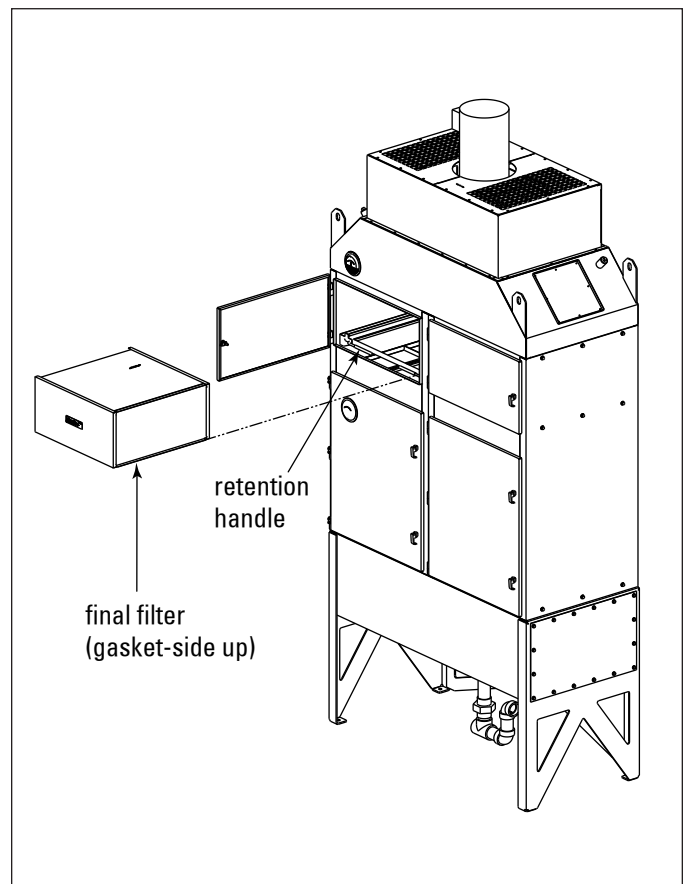

Final Filter Installation, Powered WSO 25-2 shown

### P-Trap Service

1. Place a suitable container under the P-Trap, turn the collector OFF and remove the pipe plug.
2. Allow fluid and particulate to drain.
3. Use thread sealant and replace pipe plug.
4. Refill the P-Trap with suitable fluid before restarting the collector.

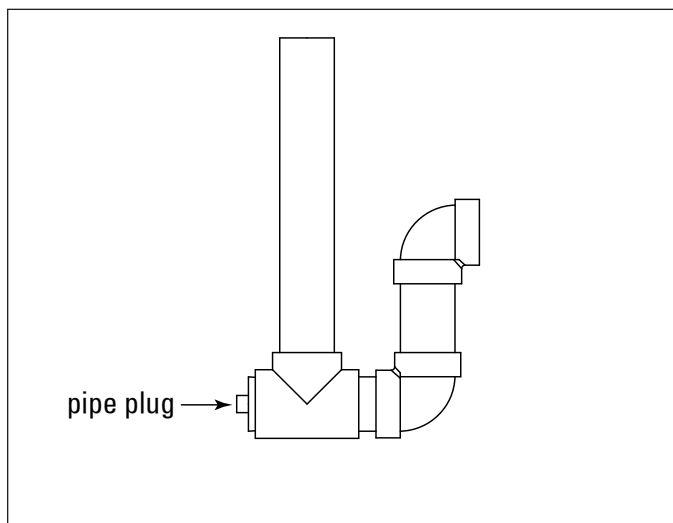

P-Trap

### P-Trap with Y-Strainer, Screen Cleaning and Removal

1. Place a suitable container under the screen clean-out valve, turn the collector OFF, close the P-Trap valve, then open the screen clean-out valve.
2. Allow fluid and particulate to drain.
3. With the clean-out valve open, slowly open the P-Trap valve. This allows fluid still trapped in the hopper to drain.

**NOTICE**

A substantial amount of fluid may be trapped in the hopper and could exceed the container capacity. Open the P-Trap valve slowly.

4. Close the P-Trap valve.
5. Unscrew the screen cap and pull the screen out.
6. Clean the screen and the inside of the Y-strainer body and re-assemble taking care to seat the screen in the body and cap.
7. Close the clean-out valve.
8. Open the P-Trap valve.
9. Refill the P-Trap with suitable fluid before restarting the collector.

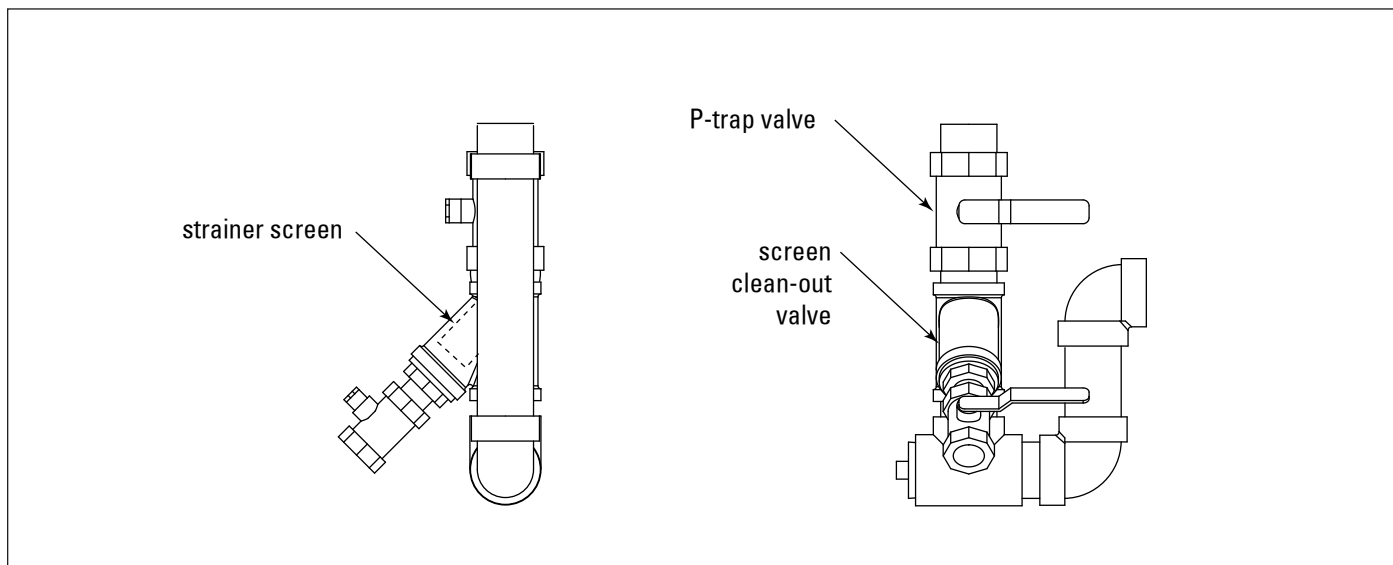

P-Trap with Y-Strainer

## Drain Collection Container

1. Turn unit OFF.
2. Remove the container by unscrewing the container from the cap. Clean the container, faucet, and reinstall.

Note: Close the faucet before turning the collector back ON.

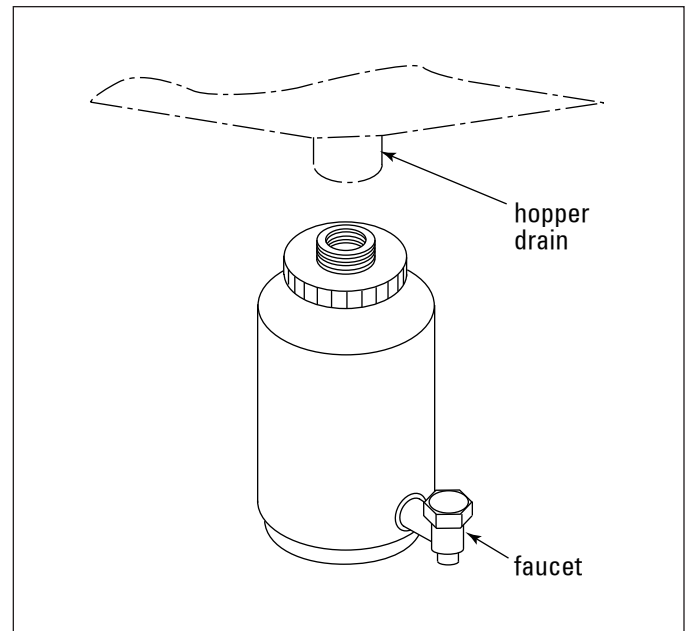

Drain Collection Container

## Optional Equipment

### Factory-Installed HEPA/95% DOP Filter

Any HEPA or 95% DOP Filter module ordered with any WSO collector comes with a factory-installed Magnehelic or Minihelic gauge for measuring the pressure drop across the filter.

On WSO 20 and 25-1, the HEPA or 95% DOP afterfilter is attached to the top of the WSO unit using side-mounted latches.

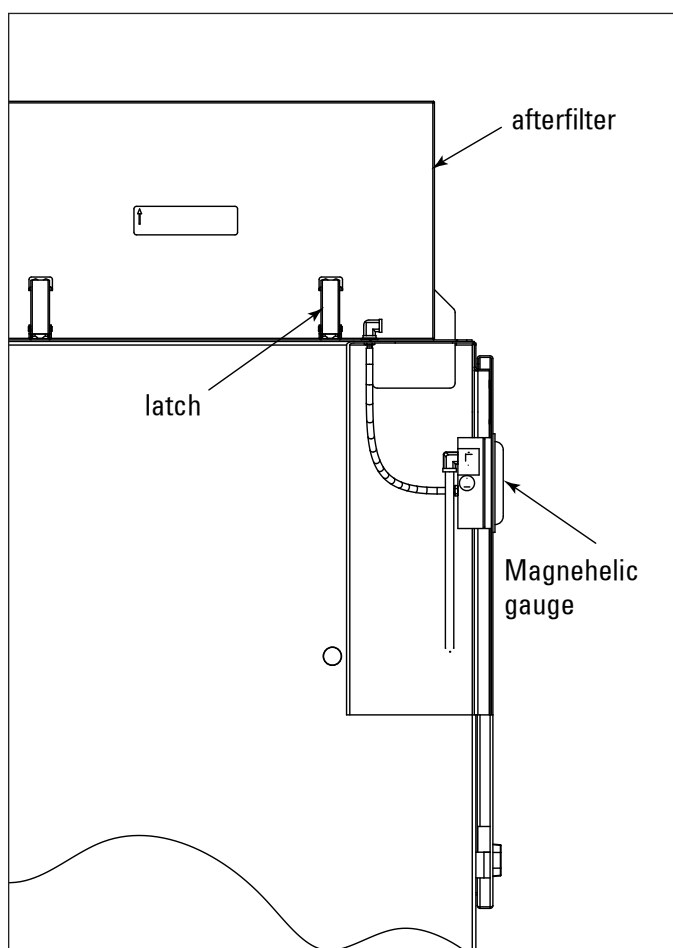

Magnehelic Gauge Configurations  
with HEPA/95% DOP Module, WSO 25-1 shown

### Field Installation (WSO 20 and 25-1)

An afterfilter installation kit is available for customers who decide to add a HEPA or 95% DOP filter to an existing field-operating WSO 20 or 25-1 unit originally configured with a standard exhaust. The field kit includes: afterfilter, latches, hardware, and Magnehelic gauge kit.

#### Latch and Afterfilter Installation

1. Turn the blower motor off.
2. Open the blower motor access door (WSO 25-1) or remove the exhaust grill by removing the 12 bolts (WSO 20). The exhaust grill on WSO 20 is not reinstalled.
3. Locate the existing four (4) sets (WSO 25-1) of 0.180 diameter latch holes on the roof.
4. Using the latch hardware provided, install the latches as shown in the Latch Installation sketch.
5. Place the afterfilter, gasket side down, on top of the exhaust outlet, and secure with the latches.

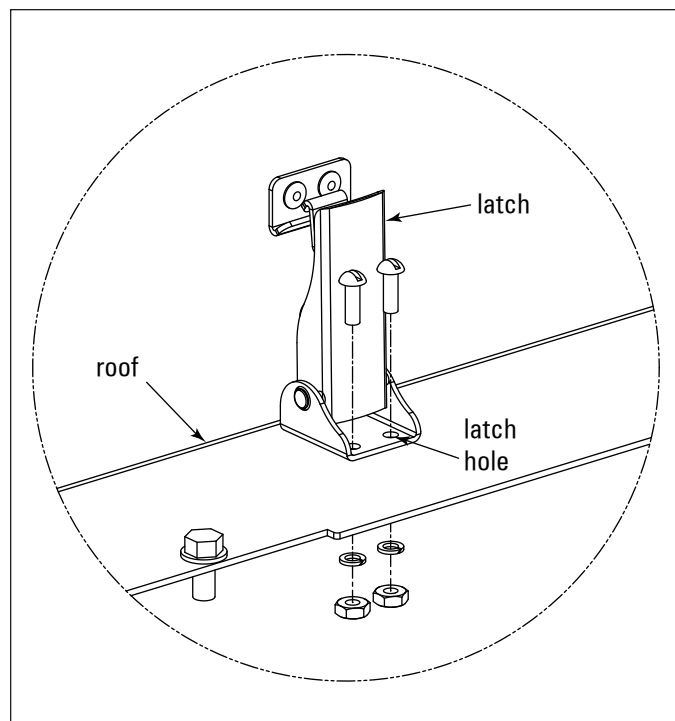

Latch and Afterfilter Installation

## Magnehelic® or Minihelic® Installation (WSO 20 and 25-1)

The Magnehelic or Minihelic Gauge is used to measure the pressure drop across the afterfilter.

1. Locate the Magnehelic or Minihelic knock-out in the top left corner of the blower motor access door (WSO 25-1) or cabinet (WSO 20).
2. Remove the diameter knockout from the door panel.
3. Install the Magnehelic or Minihelic gauge per the Magnehelic or Minihelic installation sketch.

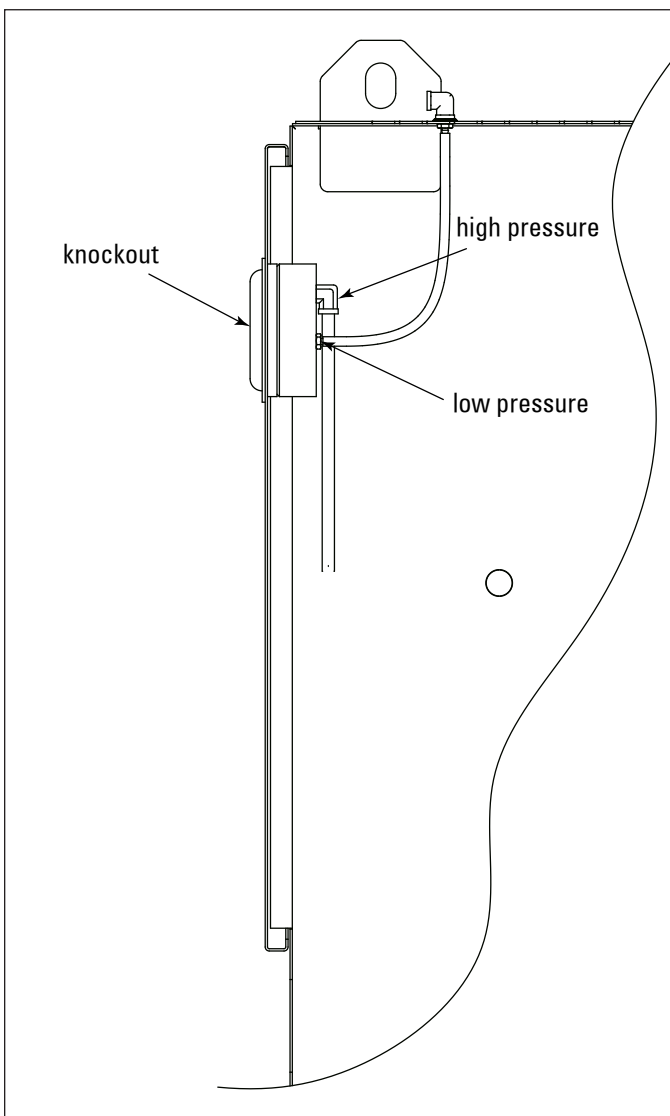

Afterfilter Magnehelic Gauge, WSO 25-1 shown

## Remote-Mount Magnehelic Installation

The Magnehelic is a differential pressure gauge used to measure the pressure difference between the clean- and dirty-air plenums and provides a visual display of filter change requirements. The high-pressure tap is located in the dirty-air plenum and the low-pressure tap is located in the clean-air plenum.

1. Choose a convenient, accessible location on or near the unit for mounting that provides the best visual advantage.

If unit is equipped with factory-installed pressure taps, skip to Step 5.

### **CAUTION**

Thoroughly clean any collected coolants or material from the collector prior to drilling to reduce the risk of combustion. Failure to comply may result in personal injury and/or property damage.

2. Before drilling, place a piece of non-combustible cloth over the filter opening in the clean-air plenum to protect them from drilling chips.
3. Place a piece of wood behind the drill location in the dirty-air plenum to protect the filters from damage by the drill bit. Use a .406-inch diameter bit to drill the holes.
4. Mount the pressure tap hardware on the clean-air plenum panel. Mount the pressure tap with the tee inside the dirty-air plenum.
5. Plug the pressure ports on the back of the gauge using two 1/8-in NPT pipe plugs supplied. Install two 1/8-in NPT male adapters supplied with the gauge into the high- and low-pressure ports on the side of the gauge. Attach the mounting bracket using three #6-32 x 1/4-in screws supplied.
6. Mount the gauge and bracket assembly to the supporting structure using two self-drilling screws.

7. Thirty-five feet of plastic tubing is supplied and must be cut in two sections. Connect one section of tubing from the gauge's high-pressure port to the pressure fitting located in the dirty-air plenum. Connect remaining tubing from the gauge's low-pressure port to the fitting in the clean-air plenum. Additional tubing can be ordered from your representative.
8. Zero and maintain the gauge as directed in the manufacturer's Operating and Maintenance Instructions provided.

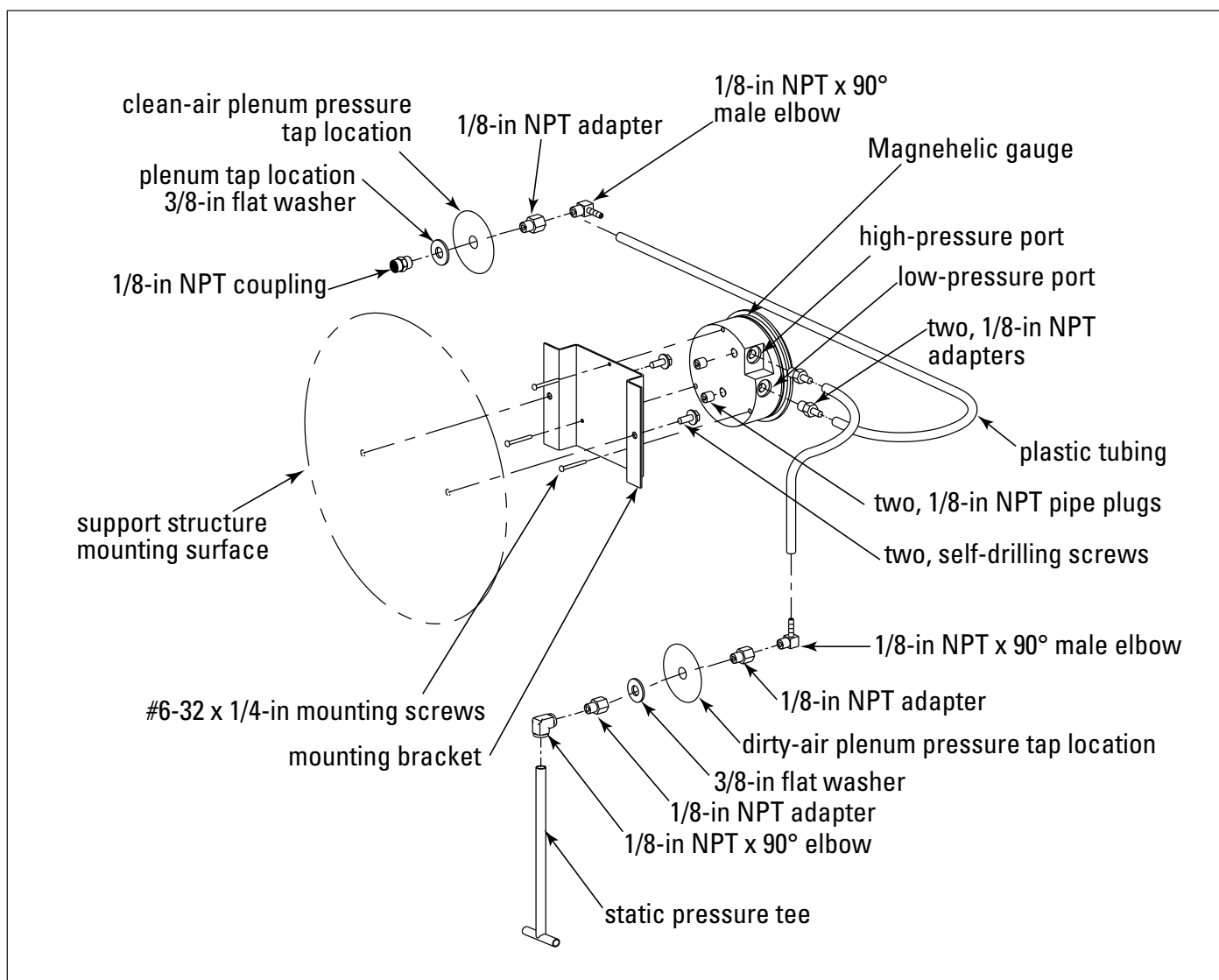

Remote-Mount Magnehelic Gauge

## Damper and Silencer, TBI (WSO Unpowered 25-2 and 25-3)

### Top Mount

1. Install the blower and motor as described in the previous section.
2. Attach the damper to the blower exhaust outlet using the hardware supplied.
3. Attach the flange to the damper using the bolts, washers, and hex nuts supplied.
4. Apply sealant to the flange and attach silencer to flange. Tighten all hardware.
5. Loosely assemble the silencer's support brackets.

### Support Brackets, Top Mount

- a. Align the pivoting support brackets to extend a minimum of 30-in from the collector and mark the drill locations.



Thoroughly clean any collected coolants or material from the collector prior to drilling to reduce the risk of combustion. Failure to comply may result in personal injury and/or property damage.

- b. Drill pilot holes with a 0.339-in bit.
- c. Secure brackets using 3/8-in thread-forming bolts.
- d. If a gap exists between the silencer and the damper, install the panel filler using the screws provided.

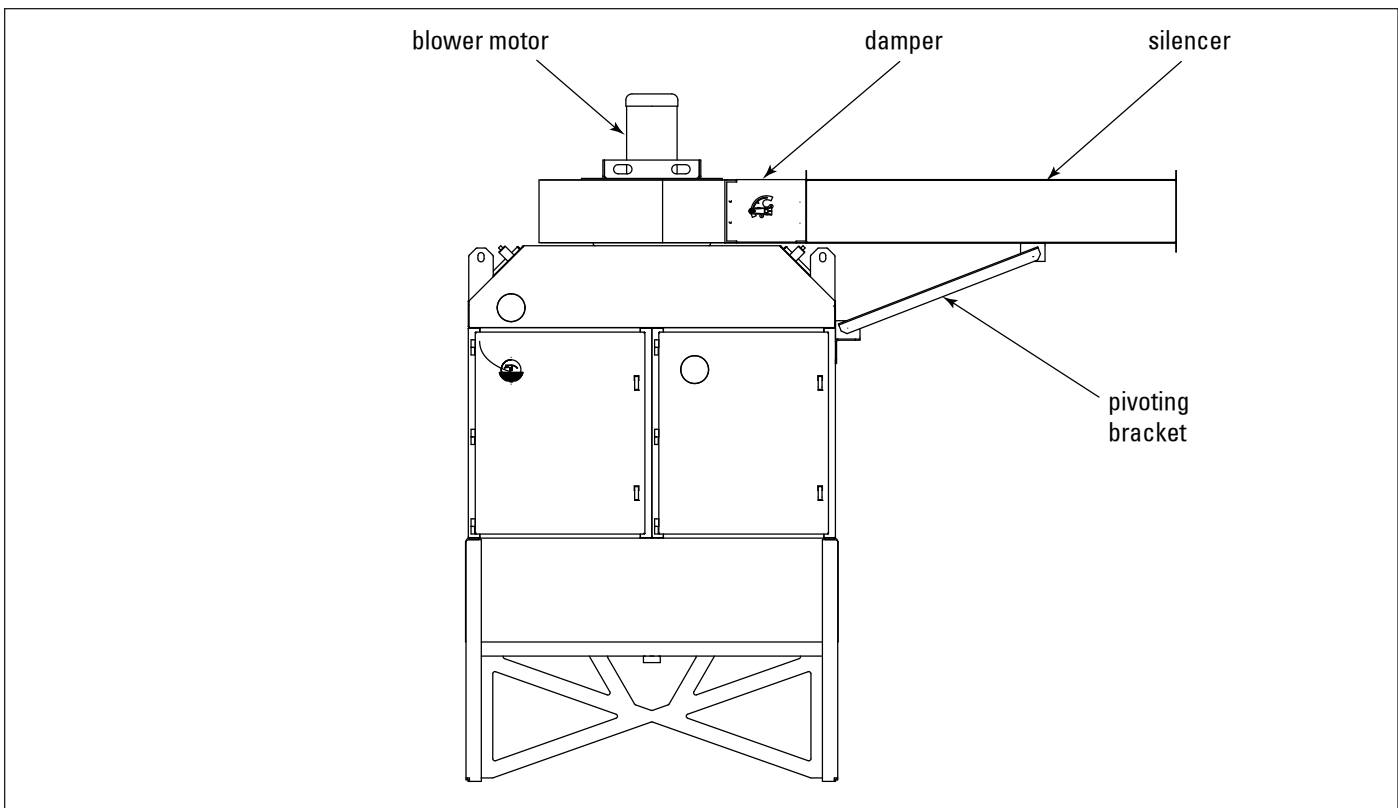

Top-Mount Silencer and Damper Installation, WSO Unpowered 25-2 shown

## Sprinkler Installation

### **CAUTION**

Sprinkler systems place a large quantity of water in the dust collector when activated. Provide adequate drainage to remove water. Excess water weight can cause the leg structure to collapse.

An optional fire control sprinklers is available for the WSO mist collector. The Donaldson Torit-supplied sprinkler requires 20 to 60 psig water pressure with a 1-in supply line. The volume of water discharged per sprinkler head at 20-psig is 6.3 gallons per minute.

### **NOTICE**

Consult with local authorities when installing fire control systems on dust collection equipment.

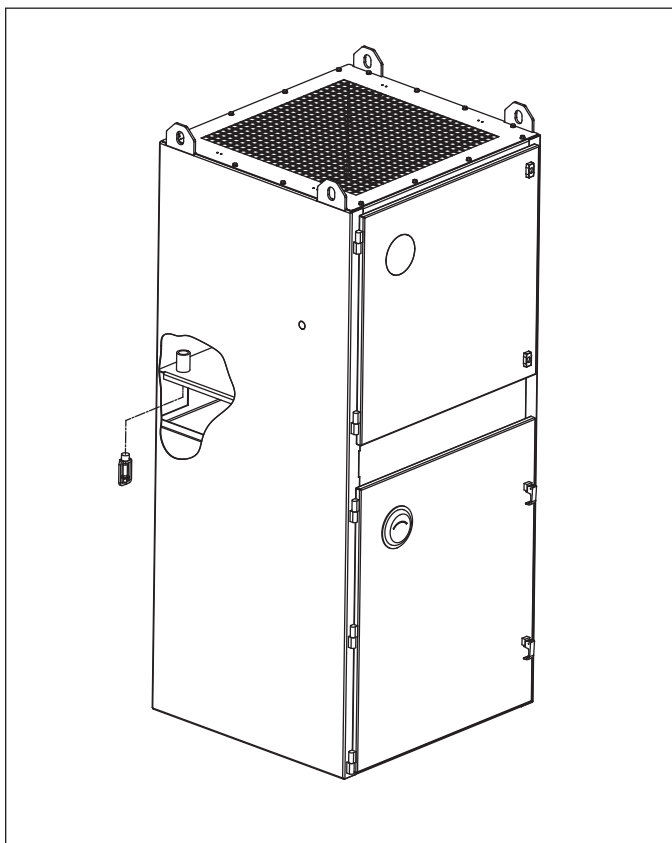

Sprinkler Installation (Blower Cabinet),  
WSO 25-1 shown

### WSO 20 Sprinkler Installation

1. Open the front access door and remove the primary filter.
2. Locate the ½-in coupling located at the top rear of the dirty air-plenum.
3. Apply pipe sealant to the sprinkler threads.
4. Thread the sprinkler into the ½-in sprinkler tap and tighten securely.

### **CAUTION**

Each sprinkler requires a 1-in supply line at 20 to 60 psig water pressure.

5. Re-install the primary filter and close the front access door.
6. At the outside rear of the unit, locate the ½-in coupling.
7. Remove the 1/2-in pipe plug from the sprinkler tap.
8. Install the water supply to the ½-in sprinkler tap coupling.

### WSO 25-1 Sprinkler Installation

1. Open the top and bottom access doors and remove the primary filter.
2. Remove the 1/2-in pipe plug from sprinkler tap.
3. Apply pipe sealant to the sprinkler threads.
4. Thread the sprinkler into the 1/2-in sprinkler tap so the sprinkler is located above the primary filter as shown and tighten securely.



Each sprinkler requires a 1-in supply line at 20 to 60 psig water pressure.

5. Remove the top exhaust panel.



Thoroughly clean any collected coolants or material from the collector prior to drilling to reduce the risk of combustion. Failure to comply may result in personal injury and/or property damage.

6. Drill a water-supply hole through the exhaust panel, adjacent to the HEPA/95% DOP if so equipped.
7. Re-install top exhaust panel and plumb the water supply to the 1/2-in pipe plug.

### WSO 25-2 and 25-3 Sprinkler Installation

1. Remove the access covers on the clean air plenum.
2. Locate the 1/2-in couplings at the angled sides of the clean air-plenum.
3. Apply pipe sealant to the sprinkler threads.
4. Thread the sprinkler into the 1/2-in sprinkler tap and tighten securely.



Each sprinkler requires a 1-in supply line at 20 to 60 psig water pressure.

5. Re-install the access covers.

6. At the outside top of the unit, locate the 1/2-in couplings.
7. Remove the 1/2-in pipe plug from the sprinkler tap.
8. Install the water supply to the 1/2-in sprinkler tap coupling.

### Drain Collection Container

The optional drain collection container is intended for use where small amounts of liquid are collected and requires regularly scheduled maintenance. Failure to empty the collection bottle will result in inlet plenum overflow.

1. Install the drain collection container during installation or after unit is in its' final operating position.
2. Turn unit OFF.
3. Remove the container by unscrewing the container from the cap. Clean the container, faucet, and re-install.

Note: Close the faucet before turning the collector back ON.

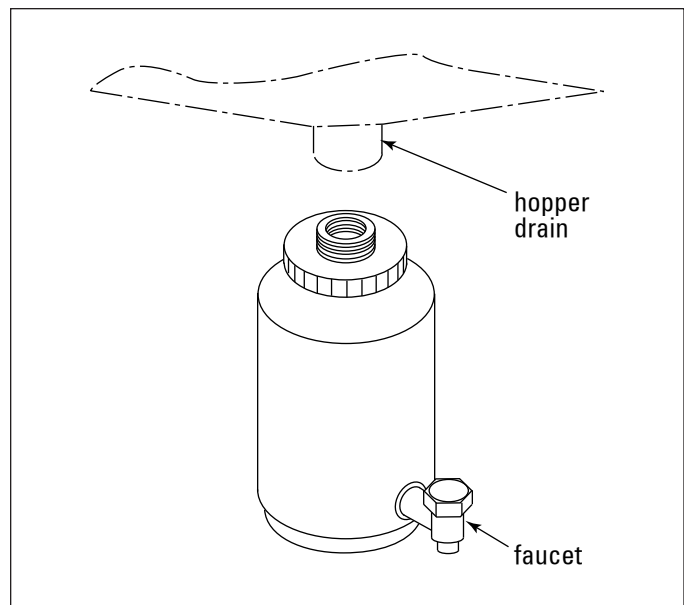

Drain Collection Container

## Troubleshooting

Problem	Probable Cause	Remedy
<b>Blower and motor do not start</b>	Improper motor wire size	Rewire using the correct wire gauge as specified by national and local codes.
	Not wired correctly	Check and correct motor wiring for supply voltage. See motor manufacturer's wiring diagram. Follow wiring diagram and the National Electric Code.
	Unit not wired for available voltage	Correct wiring for proper supply voltage.
	Input circuit down	Check power supply to motor circuit on all leads.
	Electrical supply circuit down	Check power supply circuit for proper voltage. Check for fuse or circuit breaker fault. Replace as necessary.
	Overload relay tripped	Reset. Check amp draw on motor leads.
	Defective overload heater or overload assembly	Replace as necessary.
<b>Blower and motor start, but do not stay running</b>	Incorrect motor starter installed	Check for proper motor starter and replace if necessary.
	Access doors are open or not closed tight	Close and tighten access doors. See Filter Installation.
	Electrical circuit overload	Check that the power supply circuit has sufficient power to run all equipment.
<b>Clean-air outlet discharging oil mist</b>	Filters not installed correctly	See Filter Installation.
	Filter damage, dents in the end caps, gasket damage, or holes in media	Replace filters as necessary. Use only genuine Donaldson replacement parts. See Filter Installation.
<b>Insufficient airflow</b>	Fan rotation backwards	Proper fan rotation is clockwise from the top of the unit. The fan can be viewed through the back of the motor. See Preliminary Start-Up Check.
	Access doors open or not closed tight	Check that all access doors are in place and secured.
	Fan exhaust area restricted	Check fan exhaust area for obstructions. Remove material or debris.
	First Stage filter plugged	Remove and clean or replace.
	Primary filter needs replacement	Replace filters as necessary. Use only genuine Donaldson replacement parts. See Filter Installation.
	Plugged HEPA filter	Replace filters as necessary. Use only genuine Donaldson replacement parts. See Optional Equipment.

## Troubleshooting

Problem	Probable Cause	Remedy
<b>Insufficient hopper discharge</b>	Plugged hopper screen	Remove and clean hopper screen.
	Plugged P-Trap	Clean P-Trap. See P-Trap Service.
<b>Liquid leaking from collector door</b>	Plugged P-Trap	Clean P-Trap. See P-Trap Service.
	Plugged or full drain collection container	Remove and clean or empty the drain collection container.



## The Donaldson Torit Warranty

Donaldson does not warrant against damages due to corrosion, abrasion, normal wear and tear, product modification, or product misapplication. Donaldson also makes no warranty whatsoever as to any goods manufactured or supplied by others including electric motors, fans and control components. After Donaldson has been given adequate opportunity to remedy any defects in material or workmanship, Donaldson retains the sole option to accept return of the goods, with freight paid by the purchaser, and to refund the purchase price for the goods after confirming the goods are returned undamaged and in usable condition. Such a refund will be in the full extent of Donaldson's liability. Donaldson shall not be liable for any other costs, expenses or damages whether direct, indirect, special, incidental, consequential or otherwise. The terms of this warranty may be modified only by a special warranty document signed by a Director, General Manager or Vice President of Donaldson. Failure to use genuine Donaldson replacement parts may void this warranty. THERE EXIST NO OTHER REPRESENTATIONS, WARRANTIES OR GUARANTEES EXCEPT AS STATED IN THIS PARAGRAPH AND ALL OTHER WARRANTIES INCLUDING MERCHANTABILITY AND FITNESS FOR A PARTICULAR PURPOSE, WHETHER EXPRESS OR IMPLIED ARE HEREBY EXPRESSLY EXCLUDED AND DISCLAIMED.



**Donaldson**  
FILTRATION SOLUTIONS

### Parts and Service

For genuine Donaldson replacement filters and parts, call the Parts Express Line. For faster service, have unit's model and serial number, quantity, part number, and description available.

**Donaldson Australasia**  
Tel: 1800 503 878 (AU)  
Tel: 0800 743 387 (NZ)  
Website: [www.donaldsonfilters.com.au](http://www.donaldsonfilters.com.au)

**Donaldson China**  
Tel: 400 820 1038  
Website: [www.donaldson.cn](http://www.donaldson.cn)

**Donaldson South Asia**  
Tel: +91 124 480 7536  
Website: [www.india.donaldson.com](http://www.india.donaldson.com)

**Donaldson Japan**  
Tel: +81 42 540 4114  
Website: [www.donaldson.co.jp](http://www.donaldson.co.jp)

**Donaldson Korea**  
Tel: +82 251 733 33  
Website: [www.donaldson.co.kr](http://www.donaldson.co.kr)

**Donaldson Europe**  
Tel: +32 16 383 811  
Website: [www.donaldson.com](http://www.donaldson.com)

**Donaldson Southeast Asia**  
Tel: +65 6349 8168  
Website: [www.asia.donaldson.com](http://www.asia.donaldson.com)

**Donaldson USA**  
Tel: +1 800 365 1331  
Website: [www.donaldson.com](http://www.donaldson.com)

Donaldson Company, Inc. is the leading designer and manufacturer of dust, mist, and fume collection equipment used to control industrial-air pollutants. Our equipment is designed to help reduce occupational hazards, lengthen machine life, reduce in-plant maintenance requirements, and improve product quality.